

# INPC DP022

## 55W Smart PSU for Mini-ITX Motherboards to be used in an Automotive (9-25Volt Input) Environment

ALL INFORMATION IN THIS USER MANUAL IS PRELIMINARY AND SUBJECT TO CHANGE.  
R 2.02 September 2008  
DV Industrial Computer Ltd.

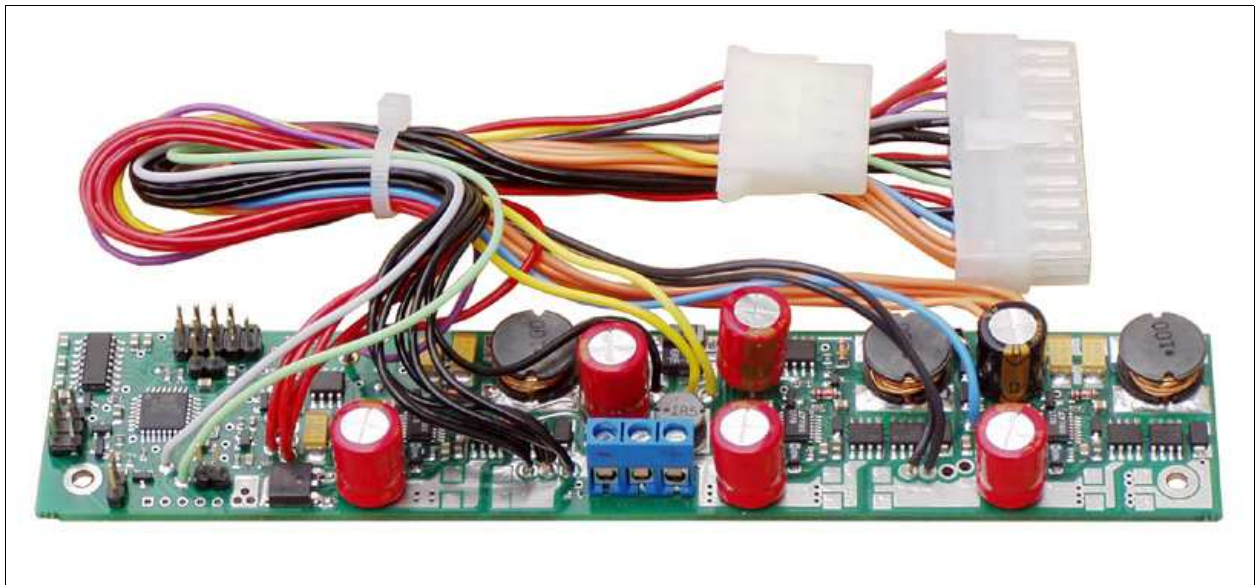

- Wide input range (9-25V)
- Suitable for automotive applications
- Suitable for battery powered applications
- Complete with start-up/shut-down control (user adjusted, saved in EEPROM)
- Compatible with most Mini-ITX boards equipped with a 20pin ATX connector
- Silent operation (fanless, no moving parts)
- Temperature control
- Low heat dissipation (efficiency over 90%)
- Chassis mountable, measurements: 34x170x24
- Connection via COM-port with computer

### Notice

This device should be attached and tuned by specialized personnel only after familiarizing with current manual! Please take a moment and read this manual before you install the DP022 in your vehicle. Often rushing into installing the unit can result in serious damage to your DP022 converter, computer and probably your car electrical system. The DP022 converter has several wires that need to be installed in various places. When installing, **always double check the polarity** of your wires with a voltmeter and by sight.

# Introduction

This manual is intended for firmware release **2.02**. The firmware release number is written on the label stick on the MCU inside the device and also this number can be obtained by a proper command sent through the serial line.

All registered trademarks are the property of their respective owners.

## Overview

The DP022 is a fully compliant ATX power supply designed to power a low power PCs from a single 12V power source. The DP022 power supply has an MCU that controls and monitors various functions of the power supply operation. Also, it realizes voltages monitoring, temperature monitoring and communication via COM-port with computer. As well the MCU realizes a WatchDog timer to supervise the computer. A LED indicator in the power supply continually reports the power system status and health. It is also used for troubleshooting. There are four main operating modes of the DP022 - Deep Sleep, Sleep, Standby, Power On. The DP022 has user selectable MCU driven timing settings, allowing you to choose various ignition/shutdown vehicle computer timing schemes (settings). These settings are user adjusted and saved in EEPROM. These settings allow to overcome the main problems of vehicle computer power supplying. One of most difficult tasks of operating a computer in a vehicle is power consumption while the computer is OFF. Even if your computer is totally OFF (standby mode), a computer will still consume a few hundred milliwatts, needed to monitor computer ON/OFF status. All power supplies provide 5Vsb (5V standby) so that the motherboard can issue at least a PSON signal. When the computer is in the suspend/sleep mode, it will consume even more power, because the RAM needs to be powered at all times. The power consumption in the suspend mode is few Watts. No matter how big your car battery is, it will eventually drain your vehicle battery in a matter of days. The DP022 is addressing these issues by cutting off the 5VSB rail after a pre-defined amount of time (timing settings). The DP022 monitors battery voltage to protect against deep discharge. When battery level drops below predefined value for more than predefined time, the DP022 will shut down and re-activate only when the input voltage is > predefined value.

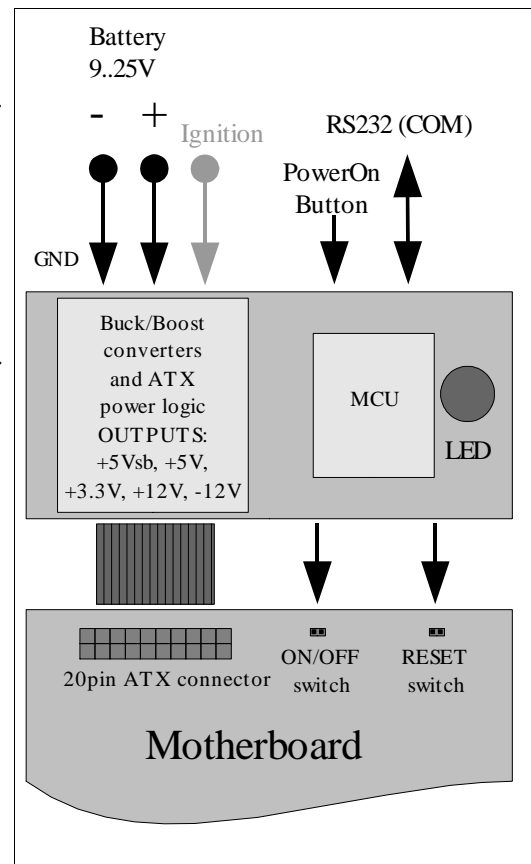

Of course, there is a traditional PC PSU mode setting with no ignition control (shutdown logic bypassed) and it can be used in non-vehicle computer applications.

## Input Characteristics

Input Connector 2 pin (PWL3)

Minimum Input Operating voltage 9V (8,5V for less than 0.01sec )

Maximum Input Operating voltage 25V (30V for less than 0.01sec)

Maximum Input Current (Sleep Mode) 20mA

Maximum Input Current (Deep Sleep Mode) 5mA

Range of Adjustable Lower Voltage Threshold 9~15V

## Output Power Characteristics

Output Connector ATX Power 20 pin (Molex P/N 39-01-2200)

### Maximum Power (at 13.5V Input – engine is running)

Output Rail	Current (Max)	Current Peak (<5 seconds)	Regulation
5Vsb	6A*	8A*	3%
5V	6A*	8A*	3%
3.3V	6A	8A	3%
12V	2A	2.5A	3%
-12V	0.1A	0.15A	10%

\*Total current on 5Vsb and 5V rails

### Maximum Power (at 12.5V Input – engine is off)

Output Rail	Current (Max)	Current Peak (<5 seconds)	Regulation
5Vsb	6A*	7A*	4%
5V	6A*	7A*	4%
3.3V	6A	7A	4%
12V	1.5A	2.0A	4%
-12V	0.1A	0.15A	10%

\*Total current on 5Vsb and 5V rails

### Maximum Power (at 10V Input – engine cranks or deep discharge)

Output Rail	Current (Max)	Current Peak (<5 seconds)	Regulation
5Vsb	5A*	6A*	5%
5V	5A*	6A*	5%
3.3V	5A	6A	5%
12V	1.0A	1.5A	5%
-12V	0.1A	0.15A	10%

\*Total current on 5Vsb and 5V rails

## Connection

NOTICE! Use the DP022 only with **low power motherboards (all VIA C3/C7 CPUs and Pentium-M / Atom)** that use V(core) from the 5V rail. **Do not use general purpose motherboards or 5.25" CDDs** as they tend to use a lot of current on the 12V rail. It's desirable to use 2.5" drives, SlimCDDs or FlashDisks as they use only current from the 5V rail. **Do not connect a Car Battery Charger** directly to the DP022.

The DP022 has several wires that need to be installed in various places. When installing, **always double check the polarity** of your wires with a voltmeter. NEVER use the cigarette plug as a power source; often the contacts are not capable of delivering high current to your PC.

### AT FIRST!

Connect a 2-pin jumper cable between JP2 and the motherboards "Reset" header. This will allow the DP022 to reset the motherboard by simulating a reset button press (POLARITY MATTERS HERE).

Connect a 2-pin jumper cable between JP3 and the motherboards "Power On" header. This will allow the DP022 to turn on and off the motherboard by simulating a power button press (POLARITY MATTERS HERE).

JP6 is a 10-pin polarized connector that is used for connection via serial line (RS-232) to the COM-port of the computer. The DP022 uses the RTS/CTS hardware handshaking of serial line flow control. However, the DP022 ignores signal on RTS line assuming that control computer is always ready to receive data. Therefore, really only four-wire link is required – SG (Signal Ground), SIN(RD) (Serial Input/Read of data), SOUT(TR) (Serial Output/Transmit of data), CTS( Clear To Send). Connect a 10-pin flat ribbon cable to COM port connector of your control computer.

RT1 (2-pin connector) is used to connect remote (0.4m) temperature sensor (thermistor). Place remote thermistor at CPU heatsink of your computer.

Connect the ATX Power Connector JP8 to the motherboard and any peripherals to JP9 connector.

### AT THE END!

Connect the “ground”, IGNITION+ and 12 Volt supply (JP1). One should to fully appreciate the function of the IGNITION+ signal (pin 2). **At the moment immediately after 12V supply voltage was applied** (a battery was connected) the DP022 analyses the value of this signal. If the IGNITION+ signal is lower than 0.5V then the DP022 will switch to the “VEHICLE MODE”. Else, if the IGNITION+ signal is higher than 3V **at the moment when the supply voltage was applied** the DP022 will switch to the “DUMB MODE”. You should eliminate the situation when this voltage is between 0.5~3V (as not defined) because the DP022 will define mode not stable. The DP022 has build-in pull-up of the IGNITION+ signal therefore in order to switch to the “DUMB MODE” you may leave the IGNITION+ signal free and do not connect it **at the moment when the supply voltage is being applied**. And vice versa, in order to switch to the “VEHICLE MODE” you must keep the IGNITION+ signal closed to the “ground” or GND (pin 3 of JP1) or provide the IGNITION+ signal voltage level less than 0.5V by corresponding current load **at the moment when the supply voltage is being applied**. One should to fully appreciate the fact that the DP022 can define its further mode of operation **SOLELY AT THE MOMENT when the supply voltage is being applied** and can be switched from the mode to mode by taking off and second applying the supply voltage with prior the IGNITION+ signal change. Later, while it is working, the DP022 analyses the “ignition” line of vehicle and controls switching on/off logic and powering of the

motherboard only if it is switched to the “VEHICLE MODE”. If the DP022 has been switched to the “DUMB MODE” when the supply voltage is being applied then the “ignition” line has the same action as the “POWER” button because this line is paralleled for analyse to the “POWER” button. If the “Ignition Key” is opened then it is the same that the “POWER” button is pressed but if the “Ignition Key” is closed then it is the same that the “POWER” button is released.

The DP022 can be tested in the lab before being installed into the vehicle. The picture shown below explains how to do it and is in use for testing and research of the DP022. Certain details need to be noted for proper bench testing. When connecting bench power use between 12 to 16 Volts DC to POWER (+) and GND (BATTERY) (-) terminals for best results. The best way to do successful bench testing is to use an adequately sized 12V battery. Bringing in the battery from the car or using an extra one that has at least a 10-AmpHour capacity will be sufficient in most cases. To aid in bench testing, it is enough do not connect IGNITION+ anywhere. The DP022 will operate as “dumb PSU” with button “POWER” control. Ri resistor (10k) simulate load in the “ignition” line of vehicle. Because of this resistor the voltage value will less than 0.5V if the “Ignition Key” is released.

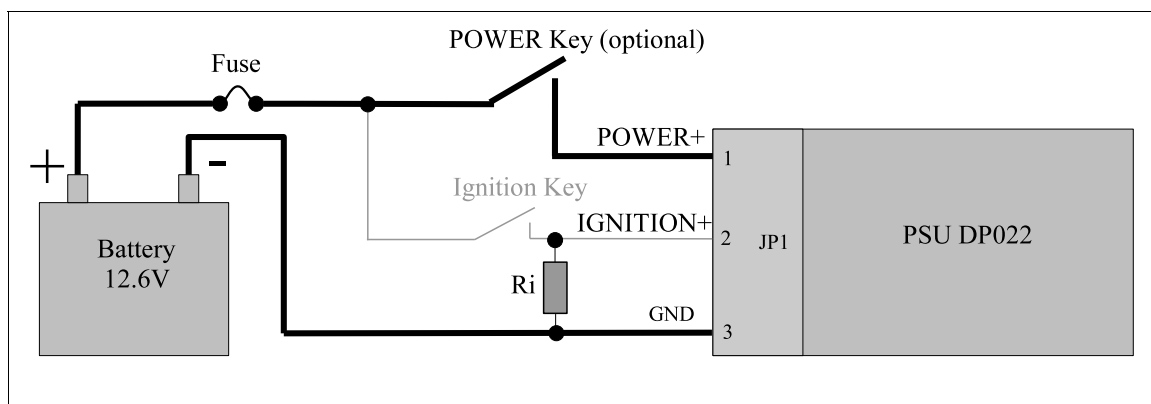

In order to connect to 12V vehicle circuit the first you should connect the GND line of the JP1 connector directly to the automotive batteries (-) terminal with heavy gauge wire. GND may also be connected with vehicle chassis if desired. Then connect the IGNITION+ (pin 2 of JP12) to the switched +12 Volt supply wire (“ignition” circuit or fuse box). This will bypass the Startup/Shutdown sequence and battery protection. At the end connect POWER line of JP1 connector directly to the automotive batteries (+) terminal with heavy gauge wire.

Apply 12 Volts to IGNITION+ by turning on the ignition or by flipping a switch and you’re ready to go!

**Do not connect IGNITION+ anywhere if you use the DP022 as a non-vehicle PSU.** In this case the DP022 will operate as “dumb PSU”.



# Operation

## “VEHICLE MODE”

If ignition is OFF and the IGNITION+ signal is LOW (about 0 Volts), then nothing happens and the DP022 stays in Sleep mode (LED Blinks as 0.03sec On / 1sec Off). The DP022 is waiting for “ignition” signal. The user steps into the automobile and turns on the key. IGNITION+ goes HI (12 Volts) and as a result the DP022 wakes up from Sleep Mode. The DP022 waits for 4 seconds, then turns on the 5Vsb rail. After another second the DP022 sends an “ON” signal to the motherboard via the 2 wires connected to the JP3 and to the motherboard’s “Power On” header. The motherboard will turn ON and your system should start booting. Ignition is ON during driving. Your computer will remain ON playing MP3s, doing GPS Navigation, etc. The automobile goes to the gas station and the driver turns off the key and IGNITION+ goes LOW. The DP022 now starts the Countdown Timer T1. The driver gets back in the car, starts the car and the computer keeps playing the MP3s without a hiccup. The user then drives home and turns off the car for the night. IGNITION+ goes low and the Countdown Timer T1 starts. The DP022 waits for “STANDBYDELAY” - then Countdown Timer T1 expires. The DP022 then sends a pulse again over JP3 pins to shutdown the computer. The shutdown pulse was successful and the computer turned off (Standby). The Countdown Timer T2 starts. The DP022 waits for “SLEEPDELAY” - then Countdown Timer T2 expires. The DP022 then goes to Sleep mode and preserves battery power. While in Deep Sleep or Sleep mode, the DP022 constantly monitors your car battery voltage levels, preventing deep discharge situations by automatically shutting down until battery levels reach safe levels again.

## “DUMB MODE”

The DP022 behaves as a regular ATX PSU with button “Power On/Off”. Of course, the DP022 monitors battery voltage to protect against deep discharge and monitors temperature and outputs. You can monitor these parameters via serial line in “DUMB MODE” as well as in “VEHICLE MODE”. Also, the WatchDog timer can be used. So, it seems that the DP022 is not a regular ATX PSU.

## LED Status Codes

LED	Buzzer	Status
2 x 0.03sec Blink / 2sec Off	0.03sec Blink / 2sec Off	Deep Sleep
2 x 0.03sec Blink / 2sec Off	0.03sec Blink / 2sec Off	Sleep
2 x 0.03sec Blink / 1sec Off	0.03sec Blink / 1sec Off	StandBy
On	1sec Blink / 0.03sec Off	PowerOn
2 x 0.03sec Blink / 4sec Off	0.03sec Blink / 4sec Off	Sleep Over Temperature
2 x 0.03sec Blink / 4sec Off	0.03sec Blink / 4sec Off	Sleep PSU Overload or Fault*

Input Voltage must go low or 'r' command must be sent to clear a fault

## Serial Line (RS232)

Notice! The DP022 PSU operates completely independent of computer's software and serial line connection.

The DP022 that is connected to control computer by serial line, operates as a terminal device with fixed connection 9600, 8 bit, no parity, 1 stop bit. Usually, computer acts as initiator of data communication – the host. The computer can send commands and data to the DP022. The DP022 responds by data block to the most commands sent from computer. The DP022 realizes a likeness of ANSI/VT100 terminal by means of subset of commands with extensions for WatchDog timer, temperature and voltage measurement channel and so on. Input from serial line is latched by incoming buffer of 23 byte size. String with 24 bytes and more will be wrapped. The DP022 starts parsing after receiving of CR(0x0d) or LF(0x0a) symbol or after overflowing of input buffer (23 bytes). Note that parameters, such as timeout for the WatchDog timer, are in ASCII digits, so 12 is represented by the characters “1” and “2”, not by a single byte with the value of 12. Also, characters are case sensitive, so /W and /w are two different commands.

## WatchDog timer

The WatchDog timer is designed to overpass a computer hanging up. Usually computer almost never hangs up. However, if it hangs up and gets stuck, usually there is nobody at the site to press the reset or nobody knows where the stuck computer is because there were no problem with it for a long time. The WatchDog timer is used just for such situations. It automatically restarts the computer that is hung up. To restart computer, the WatchDog timer closes circuit between pins 1 and 2 of JP2 connector. The WatchDog timer is off after starting of the DP022. To switch it on, the command “/WW” should be sent and timeout (number of ticks, one tick is 0.3 seconds) should be set by indicating required W, which is a value between 0 and 255. The driver program needs to set the timeout periodically to avoid the WatchDog hits and following “reset” contacts closing. Detailed information about WatchDog is given in the further sections.

## Using the serial line of the DP022 in MS Windows (MS Windows XP for example)

Assume that computer has available COM3 port that should be set as 9600, 8 bit, no parity, 1 stop bit operation. As a dialog application let us use *Hyper Terminal* that is included in MS Windows. To get it ready, open the folder **Communications** and run **Hyper Terminal** (click on “Start” button and then **Programs - Accessories – Communications**). The dialog window appears on the screen. Let us name our connection as **PSU** (arbitrary name) :

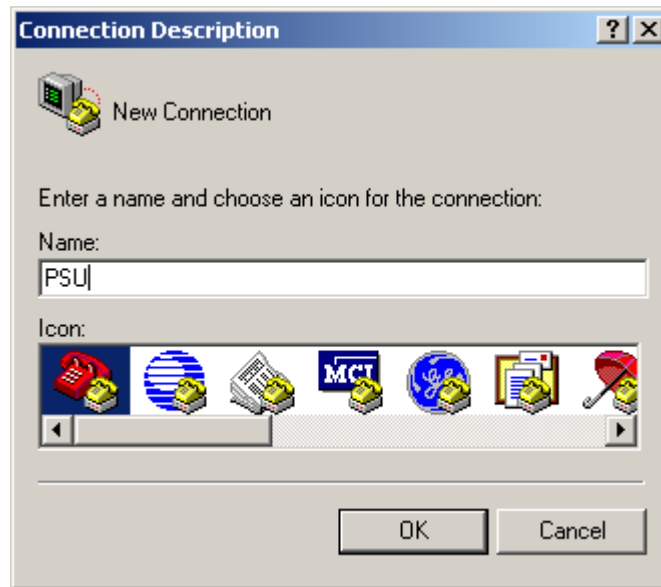

Then, select connection via serial port COM3 in **Connect To** dialog window:



And set up COM3 properties:

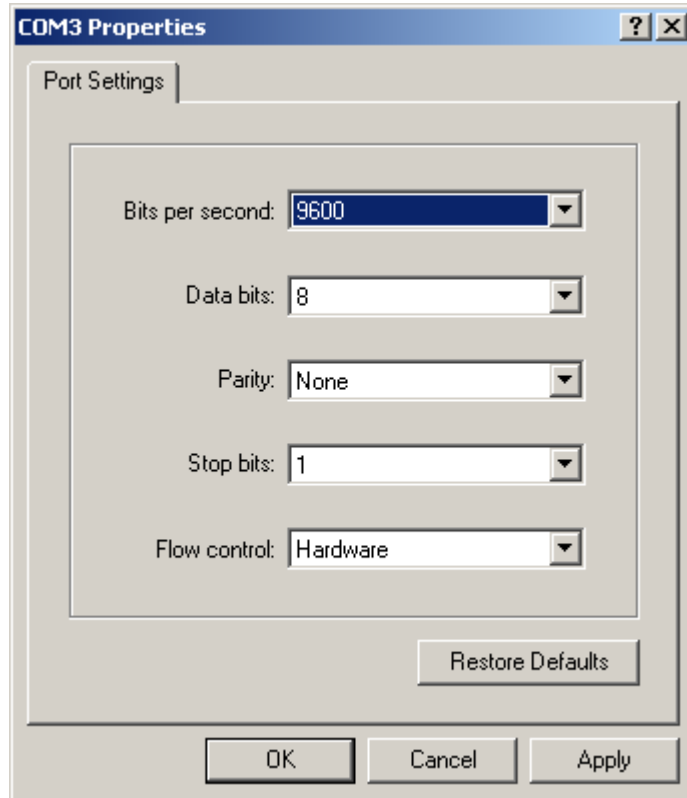

Click on **File** button in main menu of *Hyper Terminal* program and click on item **Properties** in pop up menu. In dialog window **PSU Properties** select bookmark **Settings** and select the following properties:

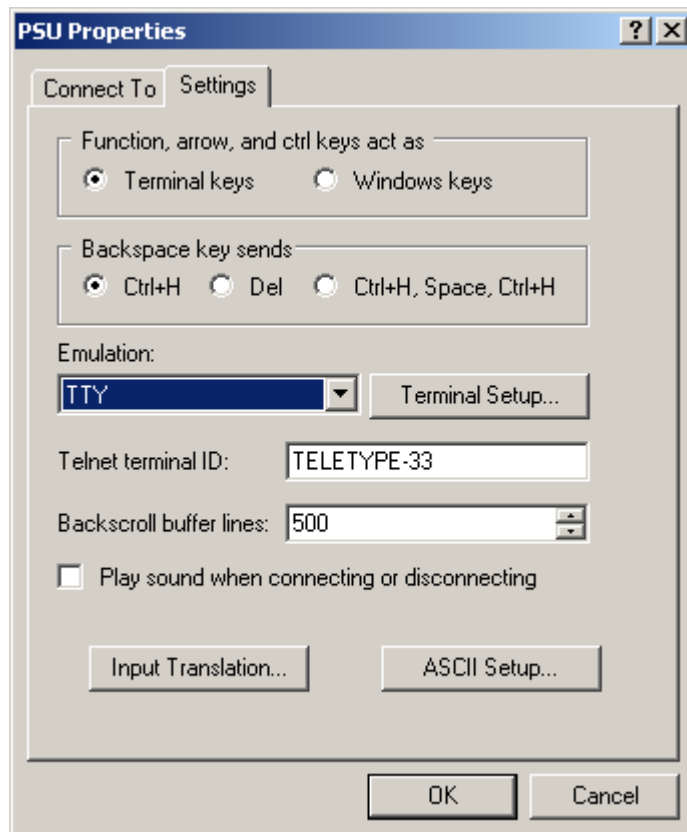

When **Hyper Terminal** configuration has been finished, everything is ready to dialog with the controller. Commands that are entered on terminal keyboard are sent to the controller **PSU** via serial port while input data flow is displayed on terminal window. In the clear terminal window enter the first command **h** (**help**) – press keys **h** and then **Enter**. As a response the controller sends firmware release number and list of commands that are supported in «*Monitor*» mode:

```

PSU - HyperTerminal
File Edit View Call Transfer Help
>h
PSU V2.02
a - All display
/b - get standBy delay. /B100 - set standBy delay 100sec (from 0 to 255)
/cb - get standBy timer Counter value
/cs - get Sleep timer Counter value
/e - get slEEp delay. /E100 - set slEEp delay 100sec (from 0 to 255)
/f - get conFiguRation. F - set conFiguRation (0 or 1)
/gl - get Low voltaGe threshold
/gh - get low voltaGe Histeresis
/Gl12000 - set Low voltaGe threshold 12000mV (from 9000 to 15000)
/Gh2000 - set low voltaGe Hysteresis 2000mV (from 500 to 4000)
h - this Help
l - Launching diagram
/m - get current Mode
/n - get Number of firmware version
r - Reset error status, switch to Standby mode
/s - get current Status
/t - get Temperature values
/u - get startUp delay in sec
/U - set startUp delay in sec
/v - get Volatage values
/w - get Watchdog value. /W100 - set Watchdog value 100tics (from 0 to 255)
>_

```

Connected 0:06:27 TTY 9600 8-N-1 SCROLL CAPS NUM Capture Print echo

If you see this list, all settings have been made correct and you can continue with study of commands. The commands have friendly interface to interact with terminal program. NOTICE! *The commands that start with symbol “/” (slash) are focused to be used with dedicated programs (of course, you can use them with terminal program). Some of commands answer with asked value, but some of commands do not. All answers that have started with symbol “/” are tailed with symbol “/”, carriage return, line feed and prompt symbol “>”*

**- a (display all)**

Press two keys **a** and **Enter**. As a response, the DP022 sends current value of temperature, output voltages, input voltage, value of Lower Voltage Threshold, contents and initial values of Timers T1 and T2, current operating mode and status:

**/b (get “STANDBYDELAY”)**

Press three keys **/ b** and **Enter**. As a response, the DP022 sends current value of “STANDBYDELAY” – initial value for T1 timer (in seconds). This value should be loaded into counter of T1 timer when IGNITION+ goes low. After that T1 timer starts time countdown. The DP022 switches to StandBy state when T1 timer expires. The “STANDBYDELAY” value has been saved in EEPROM.

**/B** (set new value of “STANDBYDELAY”)

Press keys / B and then type value of seconds from 0 to 255 and finish with Enter. You can check accuracy of setting by /b command (get “STANDBYDELAY”). If you set “STANDBYDELAY” to 0, then the DP022 will switch to StandBy state immediately after circuit IGNITION+ has gone low.

**/cb** (get counter value of T1 timer”)

Press four keys / c b and Enter. As a response, the DP022 sends current value of T1 timer counter (in seconds). At the moment when IGNITION+ goes low while the DP022 is being in PowerOn state - T1 timer starts decrementing (counter value count down). Therefore, second command that can be sent with delay of some time will result in another value with difference that corresponds to delay from first command point.

**/cs** (get counter value of T2 timer”)

Press four keys / c s and Enter. As a response, the DP022 sends current value of T2 timer counter (in seconds). At the moment when the DP022 switches into StandBy state T2 timer starts decrementing (counter value count down). Therefore, second command that can be sent with delay of some time will result in another value with difference that corresponds to delay from first command point.

**/e** (get “SLEEPDELAY”)

Press three keys / e and Enter. As a response, the DP022 sends current value of “SLEEPDELAY”, initial value for T2 timer (in seconds). This value should be loaded into counter of T2 timer when the DP022 switches into StandBy state. After that T2 timer starts time countdown. The DP022 switches to Sleep state when T2 timer expires. The “SLEEPDELAY” value is being stored in EEPROM.

**/E** (set new value of “SLEEPDELAY”)

Press two keys / E and then type value of seconds from 0 to 255 at finish with Enter. You can check accuracy of setting by /e command (get “SLEEPDELAY”). If you set “SLEEPDELAY” to 0 then the DP022 will switch to StandBy state at no time.

**/f** (get “CONFIGURATION”)

Press three keys / f and Enter. As a response, the DP022 sends current value of “CONFIGURATION” – either 0 or 1. If the value is 1, then the DP022 is configured for restart in case of recovery after a special kind of errors – revised. The first of revised errors is - *overheating* – the error that appears when even one of two thermistor will reach 65°C but disappears when both thermistors will be below 55°C. The second error is – *input voltage is lower than Low Voltage Threshold* - the error that appears when input (battery) voltage will drop lower than Low Voltage Threshold but disappears when input voltage will rise above Low Voltage Threshold value more than value of Voltage Threshold Hysteresis. The “CONFIGURATION” value has been saved in EEPROM.

**/F** (set new value of “CONFIGURATION”)

Press two keys / F and then type value of either 0 or 1 at finish with Enter. You can check accuracy of setting by /f command (get “CONFIGURATION”). If you set “CONFIGURATION” to 0 then the DP022 will not restart after recovery and will stay in mode Sleep Over Temperature/ PSU Overload or Fault till the 'r' command has been sent or input voltage is off even over temperature or low input voltage error has been recovered.

**/gl** (*get Low Voltage Threshold*) Trip Threshold Low Voltage

Press four keys / g l and Enter. As a response the DP022 sends value of Low Voltage Threshold (in millivolts). The DP022 switches into Sleep PSU Overload or Fault state if input voltage does not exceed Low Voltage Threshold. The Low Voltage Threshold value is being stored in EEPROM.

**/G l** (*set new value of Low Voltage Threshold*) Trip Threshold Low Voltage

Press keys / G l and then type value of millivolts from 9000 to 1500 and finish with Enter. You can check accuracy of setting by /gl command (get Lower Voltage Threshold).

**/gh** (*get Voltage Threshold Hysteresis*) Hysteresis Low Voltage

Press four keys / g h and Enter. As a response the DP022 sends value of Voltage Threshold Hysteresis (in millivolts). In case if the DP022 has been switched to Sleep PSU Overload or Fault state (and this error was caused by dropping of input voltage below Low Voltage Threshold value) and if the input voltage stays less than sum of Low Voltage Threshold and Voltage Threshold Hysteresis, the DP022 will stay in Sleep PSU Overload or Fault state. If input voltage rises over sum of Low Voltage Threshold and Voltage Threshold Hysteresis, the DP022 will switch into StandBy state. The Low Voltage Threshold value is being stored in EEPROM.

**/Gh** (*set new value of Voltage Threshold Hysteresis*) Hysteresis Low Voltage

Press keys / G h and then type value of millivolts from 500 to 4000 and finish with Enter. You can check accuracy of setting by /gh command (get Voltage Threshold Hysteresis).

**h** (*get list of commands*)

Press two keys h and Enter. As a response, the DP022 sends firmware release number and list of commands.

**l** (*get launching voltages table*)

Press two keys l and Enter. As a response, the DP022 sends the 20-row table with values of voltages that were measured at the moment of starting the DP022. Table contains 20 batches of voltages measured with 1 ms time slots (each batch reflected in separate row). At the start there was 20ms period to control. This table helps to evaluate load that has been connected to the DP022.

**/m** (*get current mode of operation*)

Press three keys / m and Enter. As a response, the DP022 sends numeric value that corresponds to current mode of operation – either 0 (if DUMB MODE has been set) or 1 (if VEHICLE MODE has been set).

**/n** (*get firmware release number*)

Press three keys / n and Enter. As a response, the DP022 sends firmware release number.

*/s (get current state)*

Press three keys / s and Enter. As a response the DP022 sends numeric value that corresponds to current state. The correspondence table looks as following:

<b>Value</b>	<b>Status</b>	<b>Explanation</b>
0	PowerOn	Switched on, all rails have been activated.
2	StandBy	Switched off, only 5Vsb rail has been activated.
7	Sleep	Switched off, any rail has not been activated.
8	Deep Sleep	Switched off, any rail has not been activated.
9	Sleep Over Temperature	Switched off, any rail has not been activated.
10	Sleep PSU Overload or Fault	Switched off, any rail has not been activated.

*/r (reset “error” state and switch to StandBy state)*

Press two keys r and Enter. As a response, the DP022 resets the “error” state and switches into StandBy state.

*/t (get current value of temperature)*

Press three keys / t and Enter. As a response, the DP022 sends two values of temperature that are separated by “/” symbol (slash). First value is measured by remote thermistor, second is measured by internal DP022 thermistor. You can control temperature on-the-fly by sending this command periodically.

*/u (get “STARTUPDELAY”)*

Press three keys / u and Enter. As a response, the DP022 sends current value of “STARTUPDELAY”, value of delay for startup timer (in seconds) that the DP022 make as pause after input voltage 12V has been applied. The “STARTUPDELAY” value is being stored in EEPROM.

*/U (set new value of “STARTUPDELAY”)*

Press two keys / U and then type value of seconds from 0 to 255 at finish with Enter. You can check accuracy of setting by /u command (get “STARTUPDELAY”).

*/v (get current values of input and output voltages)*

Press three keys / v and Enter. As a response, the DP022 sends five values of voltages that are separated by “/” symbol (slash). First value is input voltage (nominal value is 13.5V), second value is 5Vsb, third - 12V, fourth - 5V and fifth - 3,3V. Values have sent in millivolts. You can control voltages on-the-fly by sending this command periodically.

*/w (get current value of counter of WatchDog timer)*

Press two keys w and Enter. As a response, the DP022 sends current value of counter of WatchDog timer (in ticks, each tick is 0.3s long).

*/W (set current value of counter of WatchDog timer)*

Press two keys / W and then type the value of ticks from 0 to 255 (each tick is 0.3s long) and finish with Enter. As a response, the DP022 sends “/” symbol (slash) and just entered value which allows to check accuracy of setting.

# Configuring your operating system to be able for safe shutdown/standby with control from the DP022

(MS Windows XP for example)

**NOTE:** In order to realize such control ACPI (Advanced Configuration and Power Interface) should be used that is not a plug and play function. If ACPI is not enabled at the time your Mini-ITX motherboard is configured, you should enable it before your operating system configuring as shown below:

Go into 'BIOS SETUP UTILITY' (usually you have to power-up the computer and press the 'DEL' key on keyboard). Go to the 'Power' tab, then into 'APM' (Advanced Power Management) option and select 'Enabled'. Also, select 'Enabled' for HDD. Go back into 'Power' tab and select 'S3 State' for 'ACPI' Suspend State. If an application you have used or motherboard does not support standby mode then select 'S1 state'. Save all changes you have made and exit from BIOS setup utility.

If ACPI is not enabled at the time OS Windows is installed, you should install as shown below:

Click "**Start**" then <**Settings**> and <**Control Panel**>, then double click <**Add/Remove Hardware**> icon as result let Windows automatically detect ACPI (if it is enabled at the time your Mini-ITX motherboard BIOS is configured). Then install the proper drivers (you may need the original Windows CD). Reboot the computer to detect the newly installed ACPI component.

Then you have to configure Shutdown or Standby mode of operation for OS Windows as shown below:

Click "**Start**" then <**Settings**> and <**Control Panel**>, then double click <**Display**> icon as result access <**Display Properties**> window. Click <**Screen Saver**> tab and click <**Power**> button to access <**Power Option Properties**> window. Click <**Hibernate**> tab, check box [x] <**Enable Hibernate support**>, click <**Apply**>. Click <**Advanced**> tab and click down arrow to open choices <**Under Power buttons**> (of <**When I press the power button on my computer**>), select one of three choices **Standby**, **Hibernate** or **Power-off** options. Come back to <**Power Option Properties**> window and select <**Portable/Laptop**> under <**Power schemes**> and click <**Apply**>. Then shutdown the computer: click "**Start**" and <**Shut Down**> under <**ShutDown**> window.

## Support and warranty

Standard Hardware Warranty 1 Year.  
Installation support: 30 days via email.